

More fitting options for "duo"

Ceiling or wall - the choice is yours!

NEW

Adapter kit (item no. 927)

Installing a "duo" is now even more flexible with the new adapter brackets for ceiling mounting. The separate control unit housing can now be attached directly to the track.

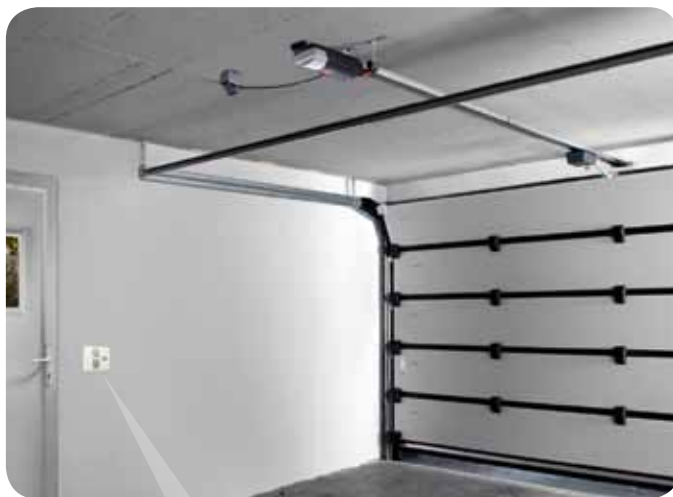
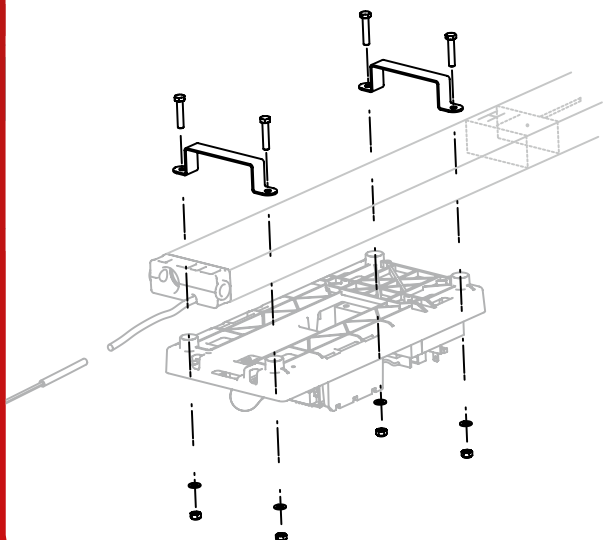

Optional extra wall switches:



3-button wireless switch, white
FM 868.8 MHz:
item no. 4762V000



Wall switch
item no. 41088

Operator unit incl. 2 handsets

duo vision 500 (500 N) item no. 3000V020
duo vision 650 (650 N) item no. 3010V020
duo vision 800 (800 N) item no. 3020V020

Matching track unit

with travel length 2,600 mm item no. 1890V000
with travel length 3,000 mm item no. 1891V000
with travel length 3,400 mm item no. 1892V000

Last updated: 06/2011. Literal errors, errors and technical changes excepted.

SOMMER
DOOR & GATE AUTOMATION

Visit our homepage: www.sommeruk.com

SOMMER Door & Gate Automation UK Ltd.
3 Harrier Court • Airfield Business Park
Elvington • York • YO41 4EA

phone: 01904 608 787

fax: 01904 608 064

email: enquiries@sommeruk.com